

HONDA GROM / MSX125 STREET SPORTS FULL SYSTEM R-77S

Product information



Be sure to read the instruction carefully before starting the work. It is necessary to follow the contents to install Yoshimura product.

- CAUTION** Before beginning installation, let motorcycle cool down.
- CAUTION** Be sure not to damage each part during installation.
- CAUTION** Torque specification must be followed. If neglected, it may cause bolt and nut to fall off and damage to Yoshimura product and motorcycle.
- CAUTION** Metal Magic sleeve is coated with heat-resistant paint. Handle with care not to be hit or scratched by surroundings as the coating may come off. When cleaning silencer, use soft cloth with dish soap but do not use metal polish or chemical cleaner.
- CAUTION** Titanium Blue sleeve is colored by anodizing. Handle with care as the color may change. When cleaning silencer, use soft cloth with dish soap but do not use metal polish or chemical cleaner.

1. Product Information :

Description	HONDA GROM / MSX125 Street Sports Full System R-77S		Cyclone Type	H43GSC111
Part Number	Stainless Sleeve (SM)	: 180A-43G-5120	Main Material	Stainless steel
	Metal Magic Sleeve (SSF)	: 180A-43G-5130	Weight [STD : 2.8kg]	(SSF) & (SM) : 2.0kg
	Titanium Blue Sleeve (STB)	: 180A-43G-5180B		(STB) : 1.8kg

2. Applicable Model :

Model	HONDA GROM(21-25) / MSX125(21-25)
-------	-----------------------------------

3. Contents:

No.	Descriptions	Part No.	Q'ty	No.	Descriptions	Part No.	Q'ty
1	Exhaust Pipe	181-43G-5U00	1	5	Cap Bolt M8x20	800-208-5020	1
2	Silencer Assy Metal Magic Sleeve	186-40A-5W21	1	6	Washer M8x20	812-108-2000	1
	Silencer Assy Satin Finish Sleeve	186-40A-5W31		7	Washer M8x25x3.2	812-108-2530	1
	Silencer Assy Titanium Blue Sleeve	186-40A-5W81B		8	Exhaust Spring	118-001-2000	2
3	Silencer Band	162-41R-G501	1	9	SD#98	138-138-4398	1
4	Silencer Band Rubber	896-016-0835	1	10	Cap Bolt M6x6 with thread lock	800-806-4006	1

Parts Diagram

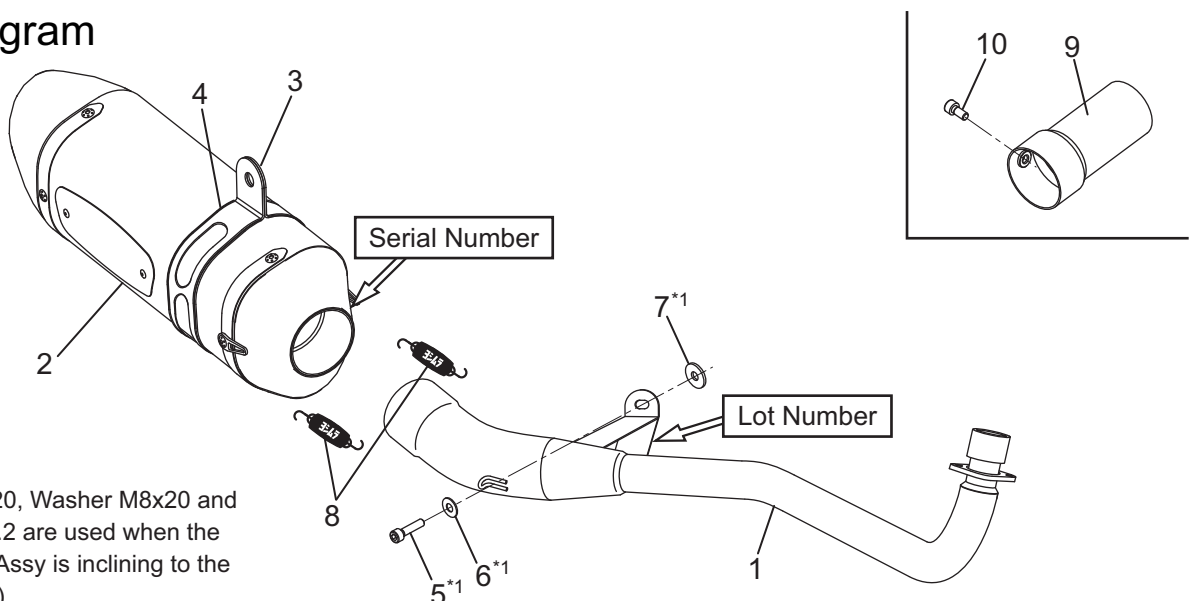

*1: Cap Bolt M8x20, Washer M8x20 and Washer M8x25x3.2 are used when the angle of Silencer Assy is inclining to the right. (See Step 9)

4. Installation steps:

- 1) Check that all the component parts are in hand.
- 2) According to Honda service manual, remove stock exhaust system (See Fig. 1).

CAUTION When removing exhaust system, be careful not to damage frame or other components.

REFERENCE Stock nuts, washer and bolt removed at this stage are reused when mounting Yoshimura product.



- 3) Replace stock gasket at exhaust port of engine with new one. Then mount Exhaust Pipe and tighten with stock nuts by hand only at this stage. (See Fig. 2 & 3)

CAUTION Use Honda genuine new exhaust gasket.

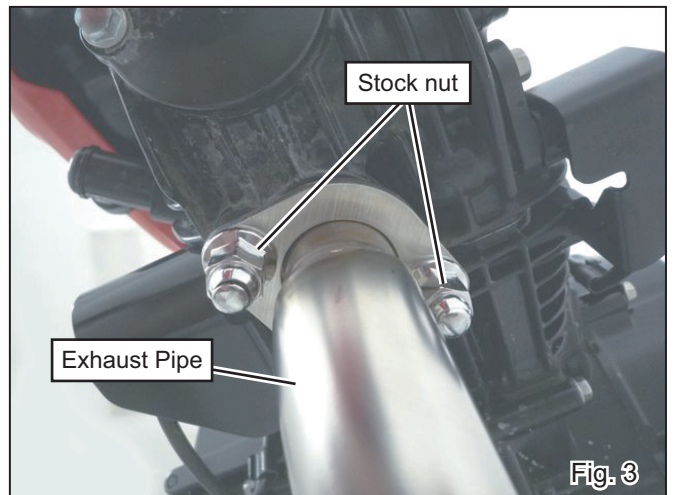
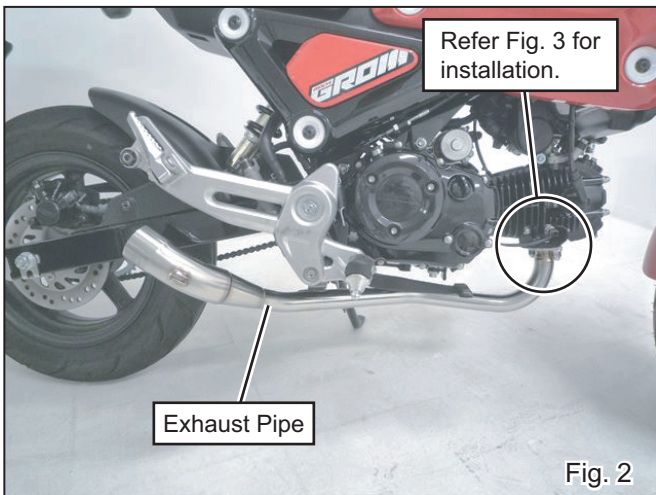

- 4) Fix exhaust pipe bracket at bolt hole underneath engine with stock bolt. Tighten bolt by hand only at this stage. (See Fig. 4 & 5)

REFERENCE Cap Bolt M8x20, Washer M8x20 and Washer M8x25x3.2 are used when the angle of Silencer Assy is inclining to the right. (See Step 9)

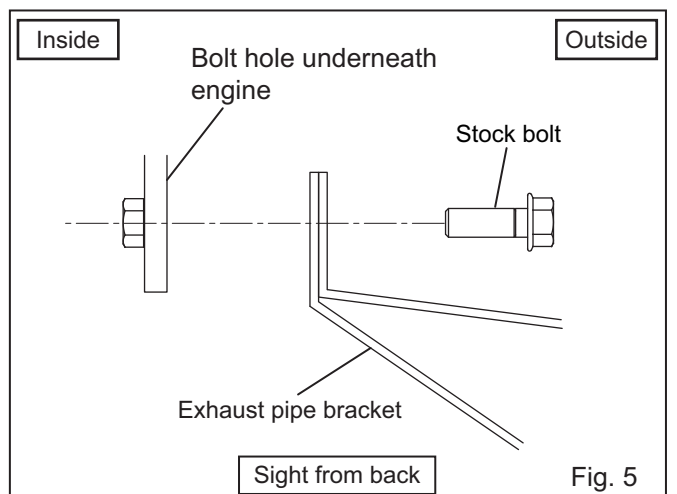
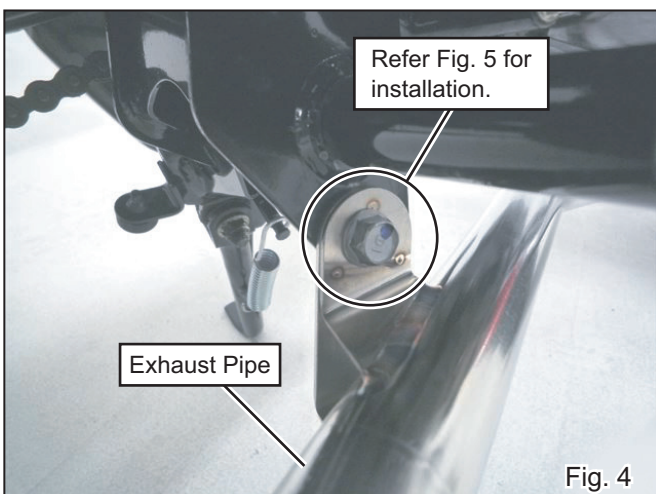

- 5) If necessary, install dB Killer SD#98 using Cap Bolt M6x6 Thread Lock (See Fig.6). Tighten and torque the bolt.

REFERENCE	Without dB Killer	; 91dB / 3,625rpm
	dB Killer SD#98	; 89dB / 3,625rpm

Tightening Torque Cap Bolt M6x6 Thread Lock : 10 Nm

CAUTION Torque specification must be followed.

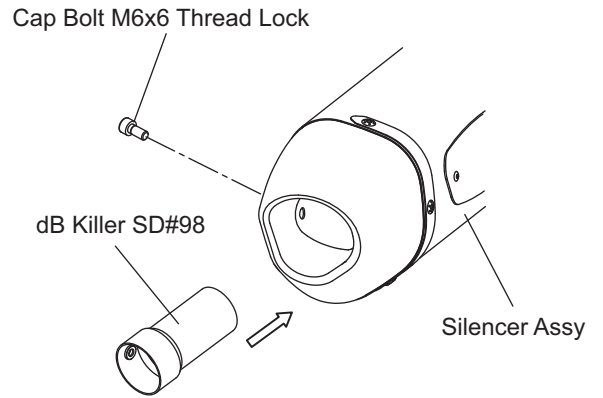

Fig. 6

- 6) Mount Silencer Assembly on Tailpipe and install 2 of Exhaust Spring (Short). (See Fig.7)

CAUTION Make sure that exhaust spring is hooked to installing tool firmly. If neglected, it may cause injury.

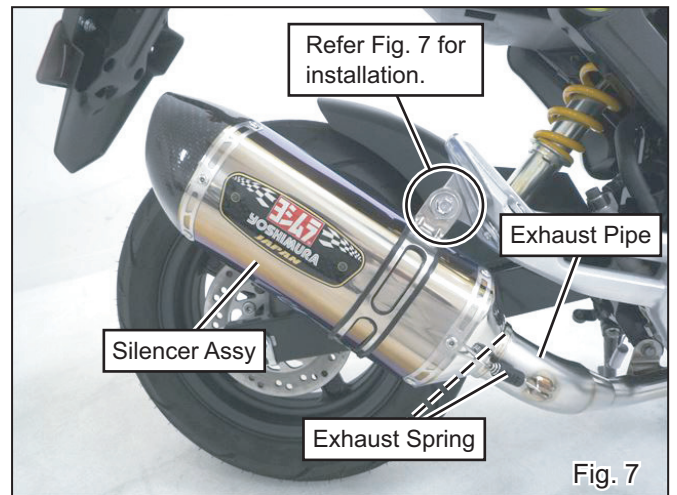
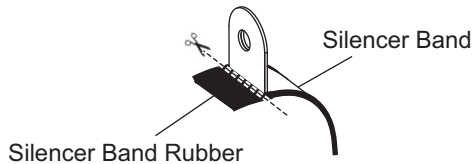

Fig. 7

- 7) Place Silencer Band Rubber inside Silencer Band, and put the Silencer Band on Silencer Assy. Then, fix the Silencer Band on stock silencer bracket with stock bolt, washer and nut removed at step 2) (See Fig. 7 & 8). Tighten bolt by hand only at this stage.

REFERENCE Cut excess of Silencer Band Rubber with scissors etc. when placing it inside Silencer Band.



CAUTION Be sure to place Silencer Band at right angles to Silencer Assy. If neglected, it may cause breakage to Silencer Band.

CAUTION Before hand-tighten Silencer Band, make sure silencer sleeve and Silencer Band fit evenly and there is no opening between them. If neglected, it may cause deformation of silencer sleeve.

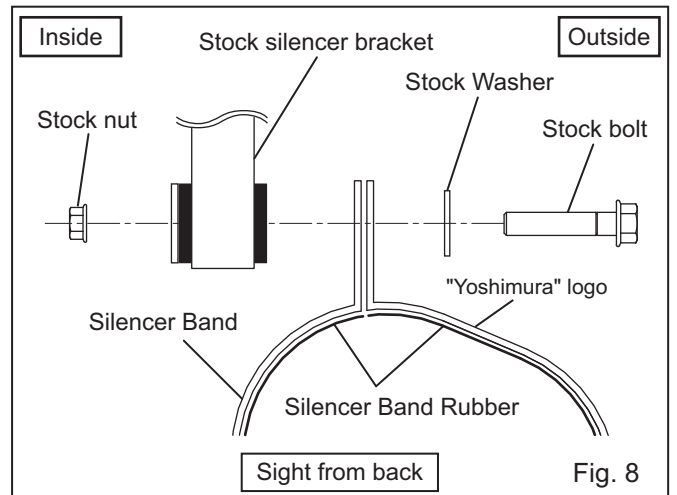

Fig. 8

- 8) Check from back and adjust angle of Silencer Assy and keep proper clearance between Yoshimura Exhaust System and other components such as swing arm. Tighten and torque 2 of stock nut at exhaust port, stock bolt at exhaust pipe bracket, and stock bolt at Silencer Band in the order (See Fig. 9 & 10 on next page).

Tightening Torque

Stock nut at exhaust port	: 15Nm
Stock bolt at exhaust pipe bracket	: 23Nm
Stock bolt at Silencer Band	: 23Nm

CAUTION Torque specification must be followed.

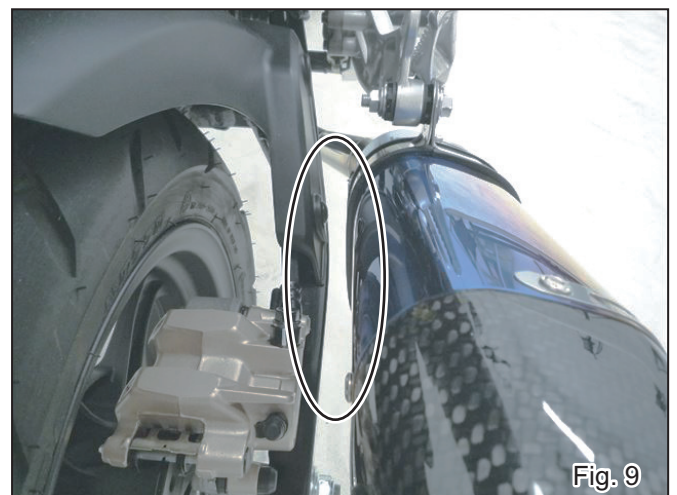

Fig. 9

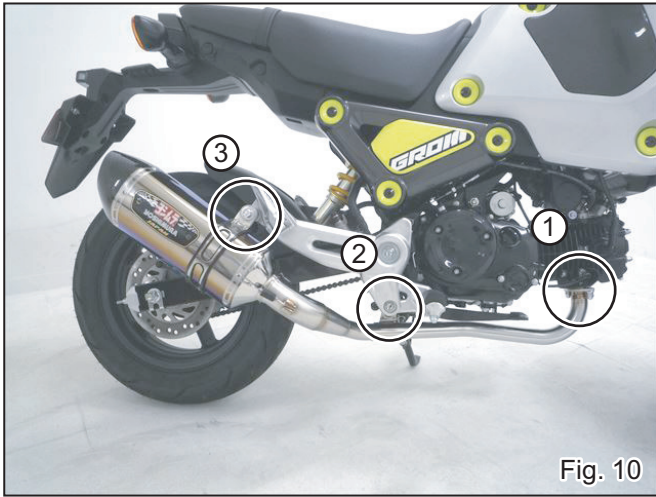

Fig. 10

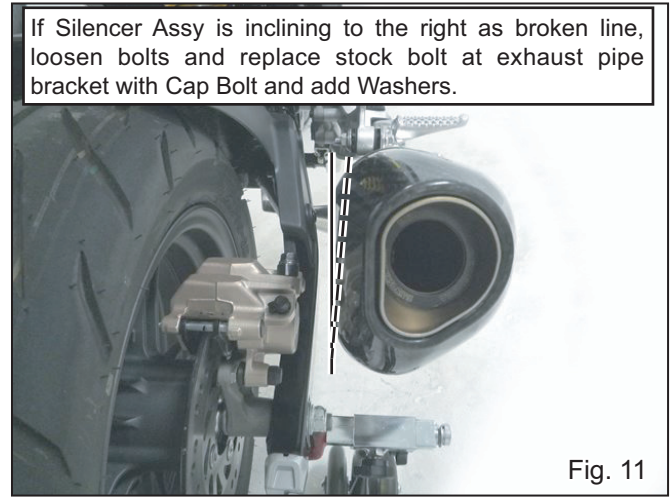

Fig. 11

- 9) Check the angle of Silencer Assy against swing arm. If it is inclining to the right, loosen stock bolts and stock nuts tightened at Step 8). Replace stock bolt at exhaust pipe bracket with Cap Bolt M8x20 and mount exhaust pipe bracket using Washer M8x25x3.2 and Washer M8x20. (See Fig. 11 & 12)
Following the Step 8), tighten stock bolts and stock nuts again with specified torque.

Tightening Torque

Cap Bolt M8x20 : 23Nm

CAUTION Torque specification must be followed.

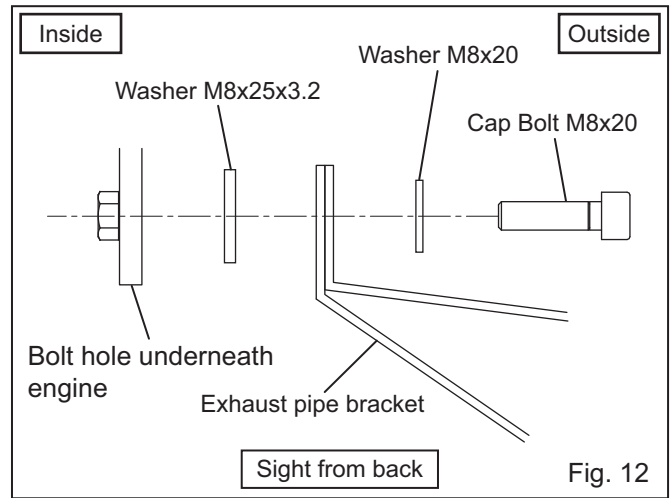

Fig. 12

- 10) Make sure there are proper clearances between Yoshimura exhaust system and other components. In case there is not enough clearance, loosen bolts and readjust the position of Yoshimura exhaust system.

- 11) It is recommended that whole exhaust to be wiped down with dish soap to remove oil and fingerprints. This will prevent from tarnishing of finish after exhaust system heats up.

CAUTION When cleaning silencer, use soft cloth with dish soap. Do not use metal polish or parts cleaner. If neglected, the paint of Emblem and Metal Magic finish may come off or Titanium Blue color may tarnish.

- 12) Warm-up engine, and inspect exhaust leaking. If "after fire" sounds severely, seal gaps of joint between pipes with heat resistant silicone gasket etc. Then, tighten all bolts and nuts further after engine cools down.

CAUTION Before beginning the work, let motorcycle cool down.

REFERENCE It is normal for new silencer to smoke until inside oil residue burns off.

After Installation



HONDA GROM ('21-'22/'23) Street Sports Full System R-77S

After Installation



HONDA GROM ('24) Street Sports Full System R-77S

! CAUTION

Titanium Blue sleeve is colored by anodizing. Handle with care as the color may change. When cleaning silencer, use soft cloth with dish soap but do not use metal polish or chemical cleaner.

! CAUTION

This exhaust is produced for track-day use or for areas where it is not necessary to use a fully legal exhaust. If it is used for racing or on a chassis dynamometer, any damage or carbon discoloration is not included in warranty.

REFERENCE

Yoshimura Japan recommends silencer inner wool replacement every 5,000km (3,000miles) in order to get Yoshimura exhaust performance fully. Climate, riding condition, and frequency of ride are direct contributing factors for inner wool worn out. Keeping high engine revolution also promotes further wool consumption. For silencer repairing, please contact local Yoshimura distributor for further information.

- CAUTIONS AFTER INSTALLATION -

- ⊙ Check each bolt sometimes to see that there is no failure condition such as poor tightening.
- ⊙ Quality control is implemented on all products. If, however, any defect or failure is found, please notify Yoshimura Japan through the selling dealer. Necessary technical service or replacing of the product will be made.
- ⊙ Due to improvement, the specifications and price of the product are subject to change without notice.
- ⊙ For any information regarding this product, please address inquiries to Yoshimura Japan Co., Ltd.

Yoshimura Japan Co., Ltd.

6748 Nakatsu, Aikawa, Aiko, Kanagawa 243-0303 Japan

Web site: <http://www.yoshimura-jp.com> E-Mail: yj-world@yoshimura-jp.com