

KAWASAKI Z900('17-'19 / '20) Street Sports Full System R-11

Be sure to read the instruction carefully before starting the work. It is necessary to follow the contents to install Yoshimura product.



- CAUTION** Before beginning installation, let motorcycle cool down.
- CAUTION** Be sure not to damage each part during installation.
- CAUTION** Torque specification must be followed. If neglected, it may cause bolt and nut to fall off and damage to Yoshimura product and motorcycle.
- CAUTION** Metal Magic sleeve is coated with heat-resistant paint. Handle with care not to be hit or scratched by surroundings as the coating may come off. When cleaning silencer, use soft cloth with dish soap but do not use metal polish or chemical cleaner.
- CAUTION** Titanium Blue sleeve is colored by anodizing. Handle with care as the color may change. When cleaning silencer, use soft cloth with dish soap but do not use metal polish or chemical cleaner.

1. Product Information :

| | | | |
|-------------|---|--------------------------|----------------------|
| Description | KAWASAKI Z900('17-'19 / '20) Street Sports Full System R-11 | Cyclone Type | K268S11C2 |
| Part Number | Metal Magic Sleeve (SM) : 180-268-5F20 | Main Material | Stainless steel |
| | Satin Finish Sleeve (SSF) : 180-268-5F30 | Weight [STD : 11.5kg] | (SM) & (SSF) : 6.5kg |
| | Titanium Blue Sleeve (STB) : 180-268-5F80B | | (STB) : 6.3kg |

2. Applicable Model :

| | |
|-------|------------------------------|
| Model | KAWASAKI Z900('17-'19 / '20) |
|-------|------------------------------|

3. Optional Part :

| | |
|------------------------------|--------------|
| Description | Part No. |
| Carbon Heat Guard Set Type-2 | 161-000-A620 |

4. Contents:

| No. | Descriptions | Part No. | Q'ty | No. | Descriptions | Part No. | Q'ty |
|-----|-----------------------|---------------|------|-----|----------------------------------|--------------|------|
| 1 | Exhaust Pipe #1 | 181-268-5F00 | 1 | 10 | Button Bolt M6x20 | 803-206-4020 | 2 |
| 2 | Exhaust Pipe #2 | 182-268-5F00 | 1 | 11 | Washer M6x13 | 812-206-1310 | 2 |
| 3 | Exhaust Pipe #3 | 183-268-5F00 | 1 | 12 | Flange Nut M6 | 823-006-1000 | 2 |
| 4 | Exhaust Pipe #4 | 184-268-5F00 | 1 | 13 | Spacer 10-30-5 | 850-010-3005 | 1 |
| 5 | Exhaust Collector | 119-501-5000 | 1 | 14 | Exhaust Spring (Long) | 118-000-1000 | 5 |
| 6 | Tailpipe | 185-268-5F00 | 1 | 15 | Exhaust Spring (Medium Floating) | 118-001-2000 | 1 |
| 7 | Silencer Assy, (SM) | 186-279-5E20 | 1 | 16 | SD#136 | 138-138-45D6 | 1 |
| | Silencer Assy, (SSF) | 186-279-5E30 | | 17 | Cap Bolt M6x8 Thread Lock | 800-806-4008 | 1 |
| | Silencer Assy, (STB) | 186-279-5E80B | | 18 | Conical Spring Washer M6 | 811-106-0000 | 1 |
| 8 | Silencer Bracket | 161-279-0200 | 1 | * | Spring Inner Tube | 118-000-1100 | 5 |
| 9 | Cap Bolt M10x65 P1.25 | 800-210-5065 | 1 | | | | |

Parts Diagram

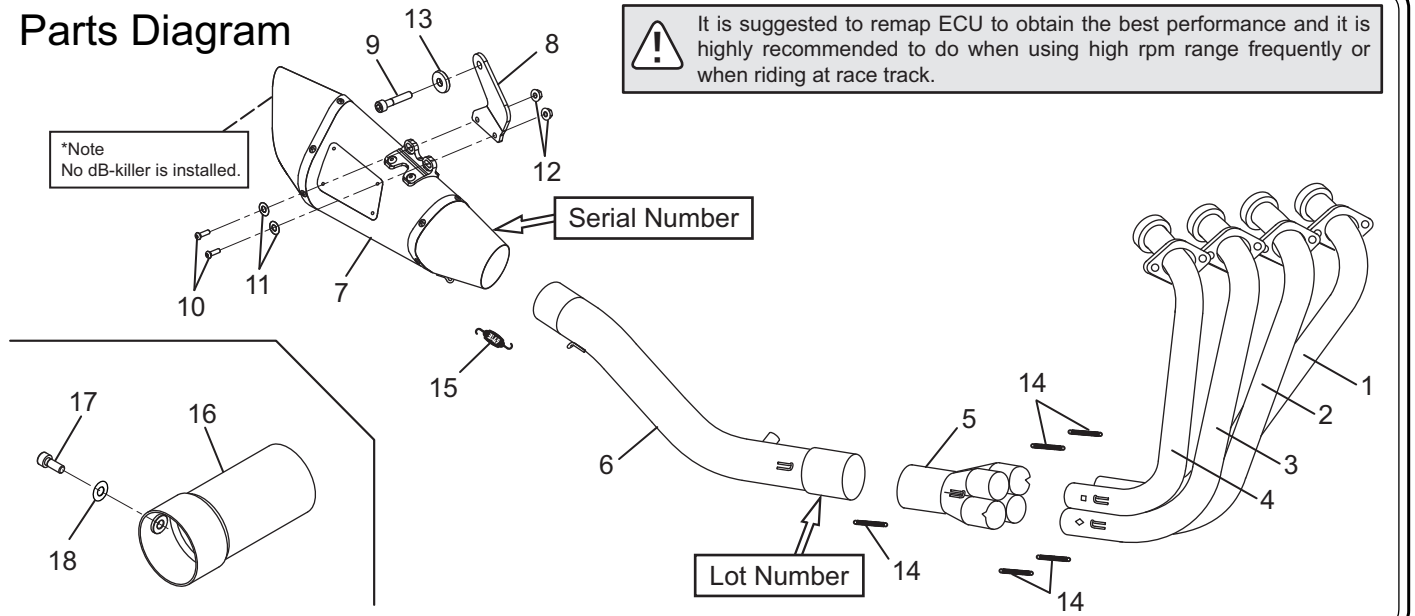

4. Installation steps:

- 1) Check that all the component parts are in hand.
- 2) According to Genuine service manual, disconnect O2 sensor coupler from vehicle and then remove whole exhaust system from vehicle after taking O2 sensor off from stock exhaust system. (See Fig. 1)
- 3) Insert Spring Inner Tube into Exhaust Spring (Long).
(See Fig. 2)

REFERENCE It is normal that Spring Inner Tube is longer than Exhaust Spring. Inner Tube is hidden when Exhaust Spring is pulled.

REFERENCE Spring Inner Tube is easily inserted by rotating.

- 4) Check sticker numbers on Exhaust Collector and install 4 of Exhaust Pipe in the right place from #4 >> #3 >> #1 >> #2 in order. Then, fit chips on Exhaust Pipe #1 and #3 to recesses on Exhaust Collector, adjust the position of Exhaust Pipe #1 and #4 to engine wide and install 4 of Exhaust Spring (Long). (See Fig. 3)

CAUTION Make sure that Exhaust Spring is hooked to spring installation tool firmly. If neglected, it may cause injury.

- 5) Peel stickers on Exhaust Collector and wipe down grease completely.

CAUTION Make sure to remove stickers and remove grease during the installation. This will help prevent tarnishing of finish after exhaust system is heated up.

- 6) Replace exhaust gaskets on all the exhaust ports with new ones and mount Exhaust Pipes assembly which is completed at Step 4 to exhaust ports and fix it with 8 of stock nut. Tighten nuts by hand only at this stage.
(See Fig. 4 & 5 on next page)

CAUTION Be careful not to damage radiator cores when mounting header assy.

REFERENCE Use new Kawasaki genuine exhaust gaskets.

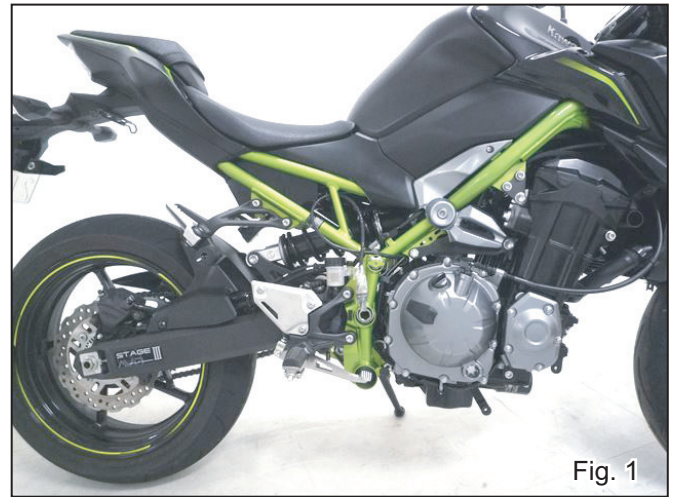

Fig. 1

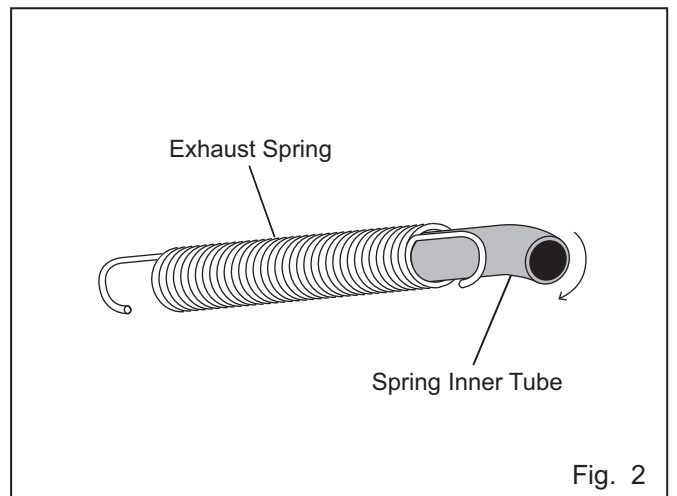

Fig. 2

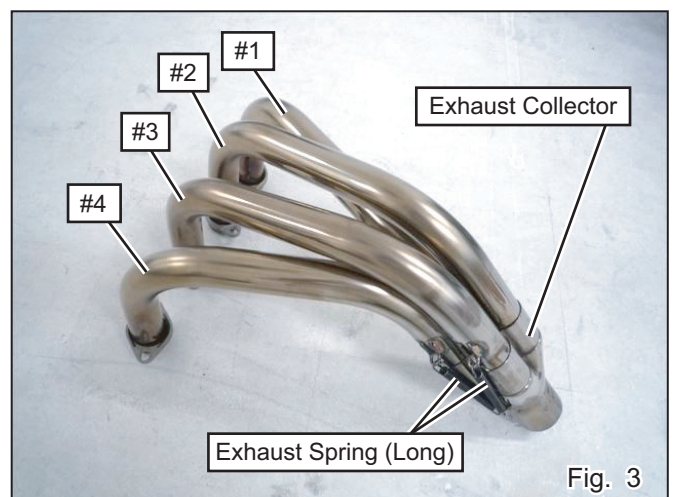

Fig. 3

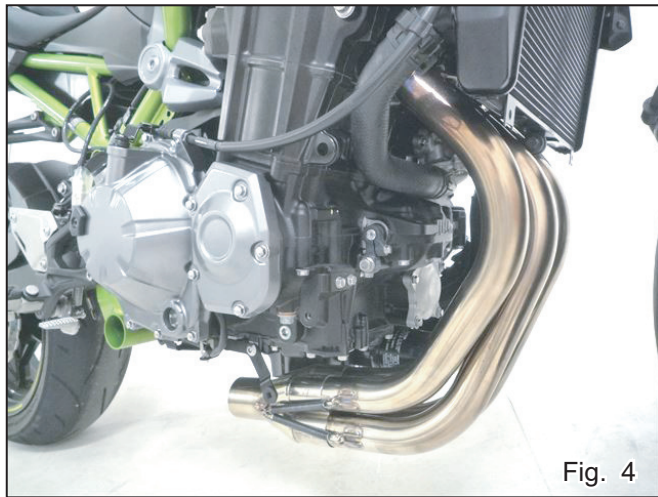

Fig. 4

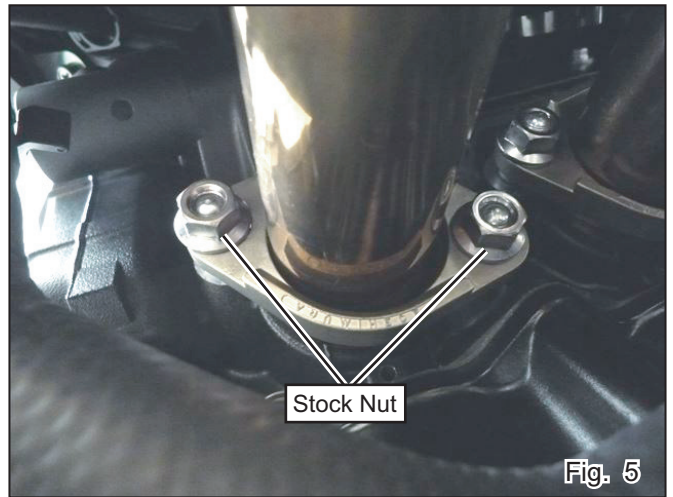

Fig. 5

- 7) Insert Tailpipe to Exhaust Collector and install Exhaust Spring (Long). (See Fig. 6)

CAUTION Make sure that Exhaust Spring is hooked to spring installation tool firmly. If neglected, it may cause injury.

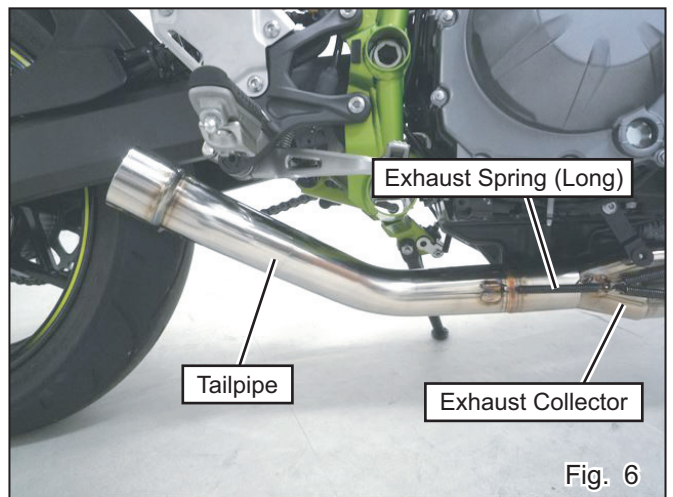

Fig. 6

- 8) Attach Silencer Bracket on to Silencer Assy with 2 of each Button Bolt M6x20, Washer M6x13 and Flange Nut M6 (See Fig. 7). Tighten the bolts by hand only at this stage.

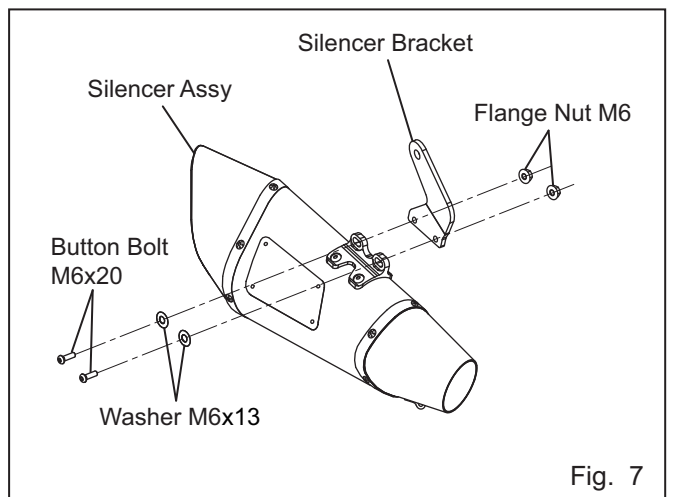

Fig. 7

- 9) Install SD#136 with Conical Spring Washer M6 and Torx Cap Bolt M6x8 Thread Lock if necessary. (See Fig. 8)

REFERENCE

| | '17-'19 model | '20 model |
|-----------------------|-----------------|-----------------|
| Stock exhaust sound : | 91dB / 4750rpm | 97dB / 4750rpm |
| With dB Killer : | 102dB / 4750rpm | 108dB / 4750rpm |
| Without dB Killer : | 106dB / 4750rpm | 111dB / 4750rpm |

Tightening Torque Torx Cap Bolt M6x8 : 10Nm

CAUTION Torque specification must be followed.

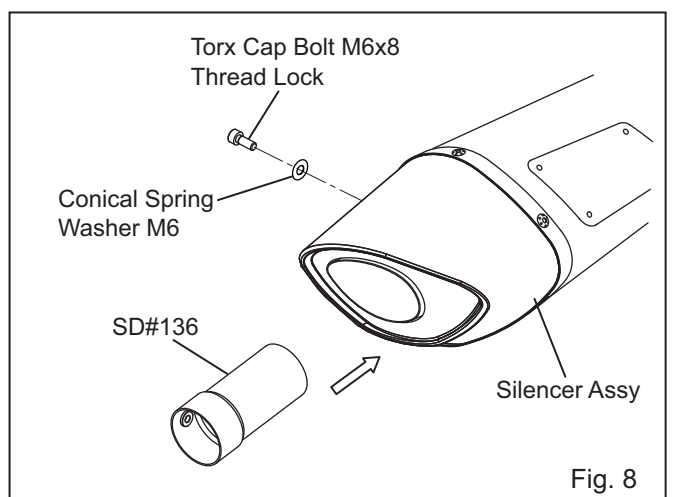
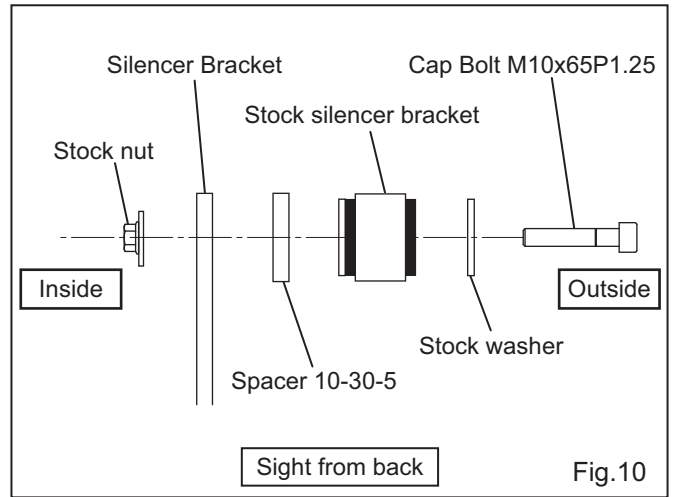
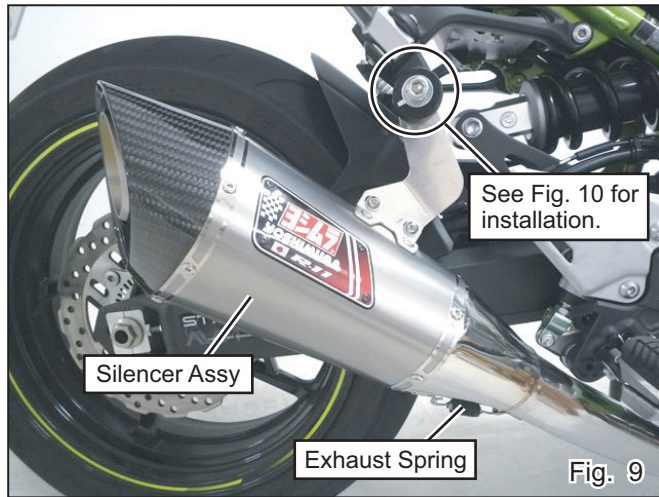

Fig. 8

- 10) Mount Silencer Assembly on Tailpipe and install Exhaust Spring. Then fix Silencer Bracket and stock silencer bracket together with Cap Bolt M10x65P1.25, Spacer 10-30-5, stock washer and stock nut. Tighten the bolt by hand only at this stage. (See Fig. 9 & 10 on next page)

CAUTION Make sure that Exhaust Spring is hooked to spring installation tool firmly. If neglected, it may cause injury.



- 11) Check that there are proper clearances between Yoshimura exhaust system and other components. Then, tighten and torque nuts at exhaust port, Silencer and Silencer Bracket in order. (See Fig. 11, 12 & 13)

Tightening Torque

| | |
|--|--------|
| Stock nut at exhaust port | : 15Nm |
| Button Bolt M6x20 at Silencer | : 10Nm |
| Cap Bolt M10x65P1.25 at Silencer Bracket | : 28Nm |

CAUTION Torque specification must be followed.



- 12) Install O2 sensor which was removed at Step 2 on Tailpipe, tighten with the specified torque and connector the O2 sensor coupler to the vehicle. (See Fig. 14)

Tightening Torque

| | |
|-----------|--------|
| O2 sensor | : 25Nm |
|-----------|--------|

CAUTION Torque specification must be followed.

CAUTION Make sure to keep O2 sensor cable away from heat source such as exhaust pipe or engine. It may cause damage of cable if neglected.

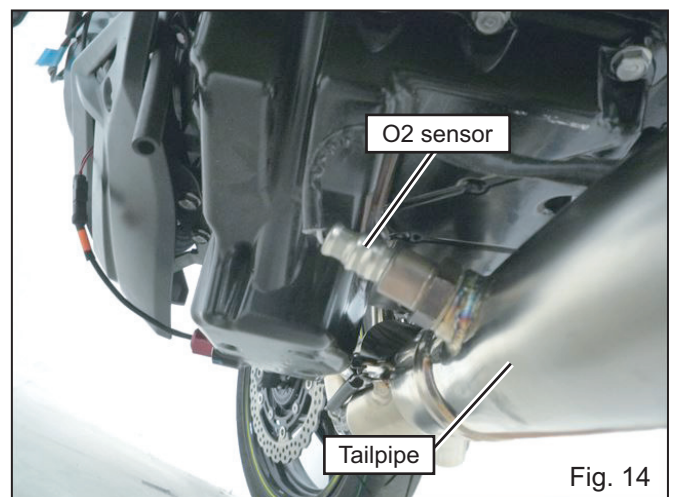

- 13) It is recommended that whole Yoshimura exhaust system is wiped down with dish soap to remove oil and fingerprints. This will prevent tarnishing of finish after the exhaust system is heated up.

CAUTION When cleaning Silencer Assembly, use soft cloth with dish soap. Do not use metal polish or parts cleaner. If neglected, the paint of Emblem may come off or Titanium Blue color may tarnish.

- 14) Warm-up engine, and inspect the exhaust leakage. If exhaust leakage is found, seal the gaps of joint with silicone gasket etc. Tighten all bolts further after engine is cooled down. If any problem is found, please follow through instruction steps carefully again.

REFERENCE It is normal for new silencer to smoke until inside oil residue burns off.



CAUTION

It is suggested to remap ECU to obtain the best performance and it is highly recommended to do when using high rpm range frequently or when riding at race track.

CAUTION

This exhaust is produced for track-day use or for areas where it is not necessary to use a fully legal exhaust. If it is used for racing or on a chassis dynamometer, any damage or carbon discoloration is not included in warranty.

CAUTION

Titanium Blue sleeve is colored by anodizing. Handle with care as the color may change. When cleaning silencer, use soft cloth with dish soap but do not use metal polish or chemical cleaner.

REFERENCE

Yoshimura Japan recommends silencer inner wool replacement every 5,000km (3,000miles) in order to get Yoshimura exhaust performance fully. Climate, riding condition, and frequency of ride are direct contributing factors for inner wool worn out. Keeping high engine revolution also promotes further wool consumption. For silencer repairing, please contact local Yoshimura distributor for further information.

- CAUTIONS AFTER INSTALLATION -

- ⊙ Check each bolt sometimes to see that there is no failure condition such as poor tightening.
- ⊙ Quality control is implemented on all products. If, however, any defect or failure is found, please notify Yoshimura Japan through the selling dealer. Necessary technical service or replacing of the product will be made.
- ⊙ Due to improvement, the specifications and price of the product are subject to change without notice.
- ⊙ For any information regarding this product, please address inquiries to Yoshimura Japan Co., Ltd.

Yoshimura Japan Co., Ltd.

6748 Nakatsu, Aikawa, Aiko, Kanagawa 243-0303 Japan

Web site: <http://www.yoshimura-jp.com> E-Mail: yj-world@yoshimura-jp.com